



WILLIBALD
RECYCLING TECHNOLOGY



SHARK 5

SHREDDING - SCREENING - TURNING

THE LATEST DEVELOPMENT IN THE SUCCESS STORY

EP 5500 Shark 5

In the last twelve years since the Shark was launched onto the market, we have sold more than 400 of this proven fast-runner series worldwide.

Since then, the shredding machine has been developed continuously further in close cooperation with our users. Today, the shredder is available in the fifth generation with five requirement-optimized rotor versions. These are even better equipped to meet the different market requirements and wide range of initial materials and convince with their high-performance capability and power.

All EP 5500 processing machines are delivered with MAN engines of the latest generation and exhaust gas class as standard. We can now offer a much wider range also as far as the drives and variety of versions are concerned. A three-axle, caterpillar or stationary version is also possible where relevant, and a full electric propulsion is becoming increasingly popular. In addition, we offer a number of other useful extras to cover all customer-specific requirements and enable cost-effective and convenient working.



Innovations



View of working/transport position

Fast, hydraulic changeover between working and transport position by radio remote control. Flexibility that pays off.



transport position



View of maintenance position

A lot of room for fast, reliable machine servicing. Convincing accessibility.

Most important new features

OF THE EP 5500 SHARK 5

- Larger rotor with a diameter of 110 cm means 30% more screen hopper area as well as higher material quality and greater throughput rate than its predecessor
- New machine control unit with modern touchscreen display and unique hand-held radio transmitter
- New hydraulic system with further options
- All electrical components centrally in a control cabinet
- Optimum interaction between the main control system and the hydraulics
- Two cylinders in the new three-part, sensor-controlled post-shredder
- Environmentally friendly exhaust gas class 5 with diesel particle filter
- Wide range of new equipment extras to choose from

Proven technology - the highlights

- All machine functions can be controlled conveniently by radio remote control
- Continuously selectable engine speed
- Effective force transmission by powerband drive
- Intelligent cooling concept by swivel fan
- Proportionally controlled feed roller and roller floor (load-dependent AIC)
- Long filling trough with clearly visible material feeding
- Robust, low-wear roller floor
- Aggressive feed roller - with hydraulic lift
- Large feed opening of 90 cm
- Rubber discharge belt hydraulically collapsible for transport, working and service position
- Extremely maintenance-friendly machine due to swivelable conveyor belt
- Error display
- Diesel consumption readout (average per operating hour)



Material discharge by rubber conveyor belt
3.8, 4.5 or 5.0 m discharge height selectable
(4.5 m = direct truck loading)

Different quick-change post-shredding
flaps for exact final graining

Swivel fan for cyclic cleaning
of the cooler surface

Conveniently and easily replaceable
tools and wearing parts

Mobile and compact, 80 km/h chassis,
only 9.95 m transport dimension

Powerful MAN diesel engines with 353 or
383 kW with the latest exhaust gas standard

YOUR MATERIAL - OUR SOLUTION

FIVE REQUIREMENT-OPTIMIZED MACHINE VERSIONS

Shark 5 - V1

Finest results:

In this modification, a **rotor with 48 fine flails** operates in combination with rakes. This achieves finest material results. Version 1 is the right decision when fine grain is required.



Green waste, corn silage, turnips
 → **output up to 240 m³/h**
 e.g. for green waste

Shark 5 - V2

Robust and fine:

This strong **rotor version with 40 flails** and more stable rakes due to the reduced number of flails enables an optimum compromise between robustness and material fineness. Version 2 is the one you want when you need decent fine grain.



Organic waste
 → **throughput up to 200 m³/h**
 e.g. horse manure

Shark 5 - V3

The all-rounder:

Here, a **rotor** operates with **16 powerful double flails**. These are equipped with **32 quickly interchangeable tips**. The universally usable shredding system of the Shark 5 in version 3 offers balanced good results in almost all areas of application.



Bark, peat processing
 → **capacity up to 210 m³/h**
 e.g. for bark

Shark 5 - V4

The universal one:

Alternatively to version 3, **32 massive single flails** can also be used. The Shark shredding system in version 4 offers longer life times and also good results for a number of materials to be shredded.



Pallets, old wood, demolition wood, root wood
 → **result up to 230 m³/h**
 e.g. for pallets

Shark 5 - V5

Master of biomass processing:

A rotor with **10 fixed shredder tools** with chopping qualities ensures excellent results in the processing of biomass. An innovative safety concept against contaminants also convinces.



Solid wood and trunks
 → **quantities up to 150 m³/h**
 e.g. for trunk wood

Compost soil, natural manure

Bio-gas substrate

Bark mulch, peat

Wood chips

Mechanically or hydraulically foldable board wall elevation on both sides

increases the filling trough volume and considerably improves working comfort. The board walls can also be folded for transport.



Crawling speed drive

enables continuous discharge of the shredded materials in closed windrows. The movement is driven by a friction wheel on two tires, controlled by control panel or remote control.



Radio remote control

allows convenient and safe machine operation of all functions and basic settings such as the feeding speed from the feeding vehicle.



Central lubrication system

supplies all lubricating points with the exact dose of required grease at adjustable intervals.



OUR ACCESSORIES VARIETY THAT CONVINCES.



Filling hopper extension

extends the filling trough by approx. 110 cm and can be folded into the transport position on the control panel or by radio remote control.



Neodymium magnet roller with collection bin

Metal fragments contained in the shredded material are attracted by strong head roller magnets and collected in a bin.



Various post-shredding flaps

Different sizes of screening hoppers are available for installation depending on the requirements for the desired end product (final grain grade). A three-part flap set is installed free of charge per machine.



Other practical machine accessories

Many other equipment extras such as belt safety package, noise protection package, bio-oil, special paintwork, etc. available on request

Other options

Hydraulic discharge flap ensures exact loading of the processed materials directly from the conveyor belt into the transport vehicle.



Water spray system prevents dust development both on the material feeder and on the conveyor belt. An ideal option when shredding pallets for example.



Additional tank large or small (360 l or 195 l) for trouble-free handling of large jobs without stopping for refueling. The large additional tank increases the fuel capacity to up to 860 liters.



LED work light (4 pieces) perfectly illuminates the working area. Ideal for use in shift operation.



Hydraulic support leg enables convenient height adjustment of the drawbar by touch display or hand-held radio transmitter.



Optical quantity measurement allows measurement of the shredded material including storage of volume, material and customer data. A fan unit is available additionally for the optical quantity measurement.



Hydraulic quick-release axle for convenient extraction of the flail axes from the rotor for quick tool changes.



Compressed air connection with practical hose reel for servicing and cleaning work on the machine.

Open for new ideas

Individual customer requests are possible after examination. We look forward to your challenges.

Important parameters at a glance

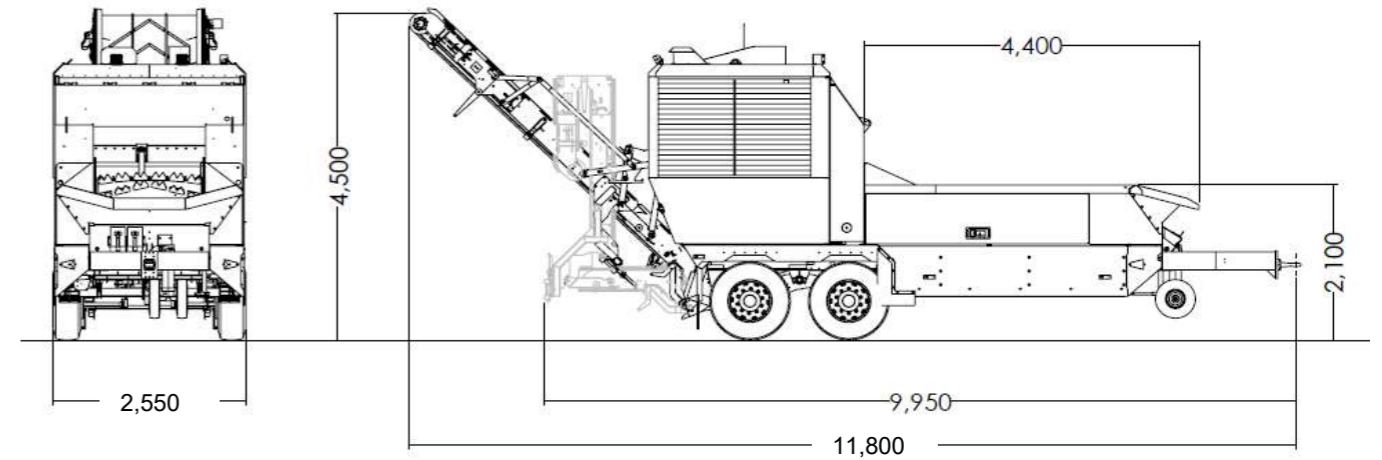

Technical data sheet EP 5500 Shark 5

Transport measurements (LxBxH) 9950/2550/4000

Engine	Standard	Upgrade
Manufacturer	MAN	MAN
Type	D2626 LE 148	D2626 LE 148
Power	353 kW / 480 HP	383 kW / 521 HP
Emission	ECE Stage V	

Chassis 2 axle central chassis for 80 km/h (50 m/h)

Permissible total weight 19000 kg

Rotor	Version 1	Version 2	Version 3	Version 4	Version 5
Approx. weight (equipped)	ca. 1650 kg	ca. 1650 kg	ca. 1850 kg	ca. 1850 kg	ca. 2000 kg
Width	1450 mm				
Diameter	1100 mm				
Flails (pcs.)	48	40	16	32	optional
Changeable tips (pcs.)	-	-	32	-	optional
Fixed tools (pcs.)	-	-	-	-	10
Milling strips/ scrapers (pcs.)	16 / 4	16 / 4	16 / 4	16 / 4	optional
Approx. hammer weight	ca. 3,5 kg	ca. 3,5 kg	ca. 23 kg	ca. 8,5 kg	ca. 35 kg
Maximal infeed height	900 mm				

Endless floor and infeed Roller infinitely variable speed

Rakes and screens position adjustable separately. The degree of opening is shown on the display

The specified parameters refer to the standard machine. Dimensions and specifications can differ due to equipment options.



Visit the Willibald YouTube channel
and see our machines in action.



WILLIBALD

RECYCLING TECHNOLOGY

HEADQUARTERS

J. Willibald GmbH
Recycling Technology
Bahnhofstr. 6
D-88639 Wald-Sentenhart

Tel.: +49 (0)7578/189-0
Fax: +49 (0)7578/189-170

info@willibald-gmbh.de
www.willibald-gmbh.de

BRANCH OFFICE

Willibald Service- &
Instandsetzungszentrum
Im Wolfsgraben 5
D-36414 Unterbreizbach

Tel.: +49 (0)36962/514-10
Fax: +49 (0)36962/514-18

info.ubba@willibald-gmbh.de